

**HORWIN**

Please do not use Vehicle before you read this manual carefully and know function of it.  
Please keep this manual carefully.

# ***EK1 PRO*** **USER MANUAL**



[www.horwin.com](http://www.horwin.com)

# EK1 PRO User Manual

Welcome to the HORWIN family!

We will help you to use the EK1 PRO e-scooter correctly and safely. To ensure your safety, please read this manual carefully before using the e-scooter for the first time, and make sure that you always meet the following requirements:

Fully understand the information in this manual, including the precautions and warnings.

HORWIN accepts no liability arising from unauthorised modifications, the use of replicas, or the installation of components that impair the performance and safety of the e-scooter.

---

Please contact the HORWIN Customer Service Centre at this e-mail address:

**[service@horwinglobal.com](mailto:service@horwinglobal.com)**

If you should have a problem with this scooter, we will be happy to help you.

We wish you a safe and pleasant ride!

## Safety Instructions

Please read this product manual carefully, and only use this vehicle if you are mentally and physically fit to do so.

Please follow the traffic rules, do not deliberately drive in reverse for long distances, do not run red lights, and do not use mobile phones while driving.

Please do not use any third-party accessories, and do not disassemble or modify the e-scooter without authorisation; otherwise, any resulting damage will be at your expense, and you will lose the right to make use of our warranty service.

Due to the continuous improvement of the product, the vehicle you purchase may differ slightly from the vehicle described in this manual. If you are unsure about the use, repair and commissioning of this vehicle, please contact our authorised specialist dealers.



Please read the following instructions carefully for your own safety and that of others:

- Before riding the e-scooter, check that all safety-relevant functions (e.g., lighting system, horn, braking system, etc.) are in working order in order to ensure road safety. If you should notice any problems, please contact your specialist dealer immediately.

- To ensure your safety, wear a safety helmet, gloves and appropriate protective equipment when driving.
  - Please make sure that you are in good health and not tired. Please do not ride your scooter if you have consumed drugs, medication, alcohol or impairing substances.
  - Please observe the traffic regulations and adjust your speed according to the weather and road conditions.
  - Do not park the vehicle in unauthorised locations (e.g., in escape routes, fire brigade access roads, restricted areas, etc.)
  - We do not recommend charging or parking the electric scooter in the immediate vicinity of flammable materials. Charging should always be done under supervision.
-

## Product Overview

Schematic representation of the vehicle

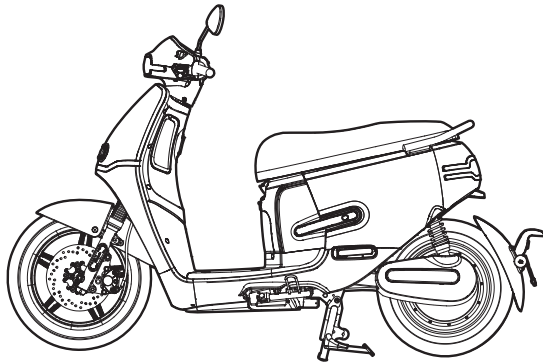

## Description of Parts

Left Side

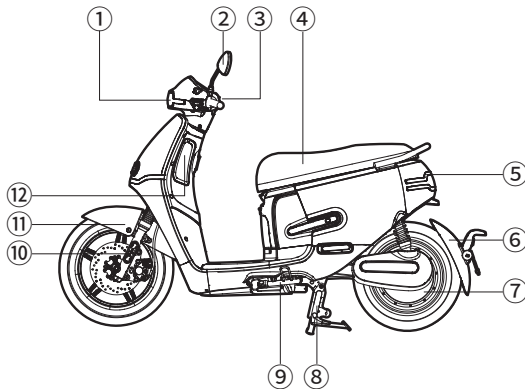

- ① Headlight
- ② Rear-view mirror
- ③ Left combination switch
- ④ Seat
- ⑤ Tail light
- ⑥ Rear fender
- ⑦ Hub motor
- ⑧ Centre stand
- ⑨ Side stand
- ⑩ Front shock absorber
- ⑪ Front fender
- ⑫ Storage compartment  
(built-in USB charging socket, max. consumption 1 A, voltage 5 V DC)

## Right Side

- ① Throttle
- ② Right combination switch
- ③ Ignition lock
- ④ Daytime Running Lights
- ⑤ Reflector
- ⑥ Footboard
- ⑦ Cover of the rear swingarm
- ⑧ Rear shock absorber
- ⑨ Rear armrest
- ⑩ TBOX

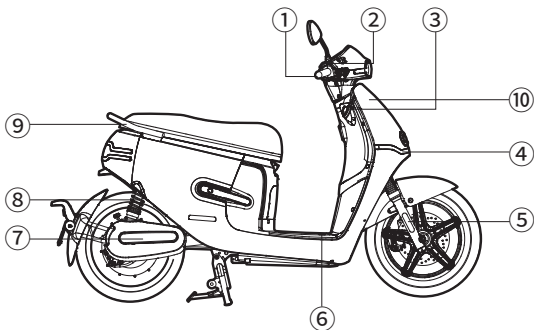

## Display/Switch Assembly

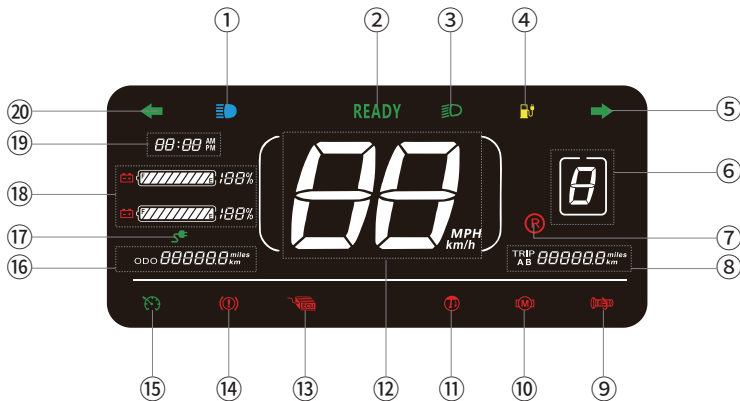

### ①. Low beam indicator

This indicator lights up when the low beam is switched on.

### ②. Standby status

Indicates that the vehicle has entered a state ready to ride. Rotate the throttle grip to move the vehicle forward.

### ③. High beam indicator

This indicator lights up when the high beam is switched on.

### ④. Low battery indicator

When the power is less than 15%, the indicator lights up.

### ⑤. Indicator, right

This indicator light flashes when you press the right indicator.

### ⑥. Gear display

Displays the currently selected riding mode.

- The maximum speed in the 1st riding mode is up to 25 km/h
- The maximum speed in the 2nd riding mode is up to 35 km/h
- The maximum speed in the 3rd riding mode is up to 45 km/h

### ⑦. Reversing light

This icon will light up while reversing.

### ⑧. Trip odometer

Display of the current distance travelled (automatic reset after restart).

### ⑨. Throttle grip indicator light

The indicator lights up if the throttle grip is not in the starting position (zero position) or is defective.

### ⑩. Motor warning light

When there is a motor fault in the vehicle, the indicator lights up.

### ⑪. Side stand indicator

Indicates whether the side stand is folded out.

### ⑫. Speed per hour

Displays the current speed (in km/h or mph) .

### ⑬. Controller warning light

This indicator lights up if the controller has a fault.

### ⑭. Throttle grip indicator

The indicator lights up if the throttle grip is not in the starting position (zero position) or is defective.

### ⑮. Cruise control

During the riding, press the button to activate cruise-control, and it will adjust the output power automatically to maintain the current speed. The cruise control can be cancelled by press it again.

\*(It can be also cancelled by any action of brake or handle bar)

### ⑯. Total mileage

Display of the total mileage reading.

### ⑰. Charging light

When it is on, it means it is charging

### ⑱. Battery A/B Indicator

Displays the current battery level as a percentage.







### ⑲. Current travel time

Display of the current travel time(automatic reset after restart).

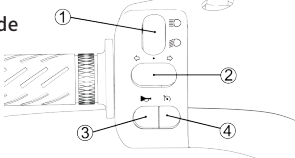
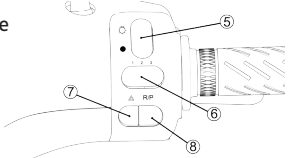
### ⑳. Indicator, left

This indicator light flashes when you press the left indicator.

# Combination switch

Left side	Right side
 <p><b>1 High/low beam</b></p> <ul style="list-style-type: none"><li>• Press the switch upwards to switch on the high beam.</li><li>• Press the switch down to switch on the dipped beam.</li></ul>	 <p><b>5 Main lighting</b></p> <ul style="list-style-type: none"><li>• Press the switch down to switch off the main lighting.</li><li>• Press the switch upwards to switch on the main lighting.</li></ul>
<p><b>2 Indicator</b></p> <ul style="list-style-type: none"><li>• Press the switch to the left to switch on the left indicator.</li><li>• Press the switch to the right to switch on the right indicator.</li><li>• Move the switch to the centre position to switch off the indicator.</li></ul>	 <p><b>6 Riding mode selector switch</b></p> <ul style="list-style-type: none"><li>• Left position: 1. riding mode</li><li>• Centre position: 2. riding mode</li><li>• Right position: 3. riding mode</li></ul>
 <p><b>3 Horn</b></p> <ul style="list-style-type: none"><li>• Press the horn button to sound the horn signal.</li><li>• The horn signal ends when the horn button is released.</li></ul>	 <p><b>7 Hazard warning lights</b></p> <ul style="list-style-type: none"><li>• Press the button to activate the hazard warning lights.</li><li>• Press the button again to deactivate the hazard warning lights.</li></ul>
 <p><b>4 Cruise control</b></p> <ul style="list-style-type: none"><li>• Press the button to run the scooter at the current speed.</li><li>• To deactivate the cruise control, press this button again or apply the brake.</li></ul>	 <p><b>8 Start\Reverse switch</b></p> <ul style="list-style-type: none"><li>• Press the button to switch to standby/READY mode.</li><li>• Press and hold the button to activate reverse mode and re lease it to return to forward mode.</li></ul>

# Vehicle lock



Starting the scooter

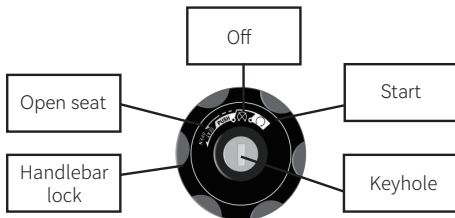

Open seat



Handlebar lock



## Switching the scooter on and off

Insert the mechanical key and turn it to the **"Start"** position to switch on the vehicle. Turn the key back to the **"Off"** position to switch off the vehicle.

## Opening the seat

1. Insert the mechanical key and turn it to the **"Open seat"** position to unlock the seat.
2. If the radio remote control is less than approx. 2 metres away, the seat can be opened by pressing it and turning it to the left.

\*assuming the radio remote control and alarm system are working correctly.

## Handlebar lock

Turn the handlebars to the furthest left position. The handlebars are locked by pressing and turning the key anti-clockwise to the **"handlebar lock"** position.

# Battery and Charger

## Instructions for using batteries

The vehicle has two charging modes: external charging and in-vehicle charging.

### External charging mode

---

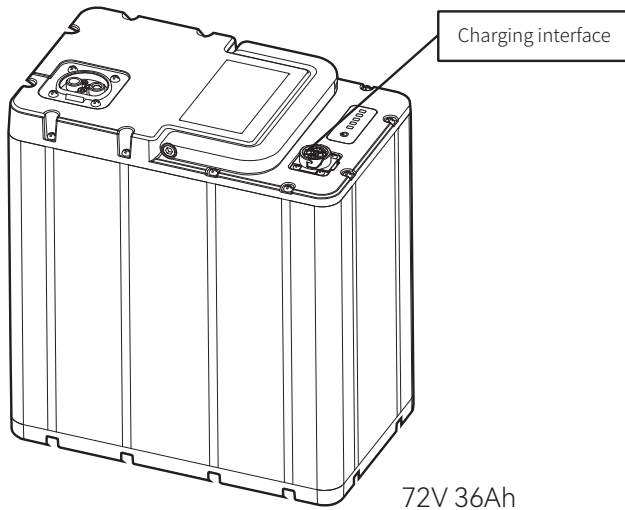

First connect the charger to the battery interface, and then to the socket. If the charging process does not start automatically, press the charging indicator button.

## In-vehicle charging mode

---

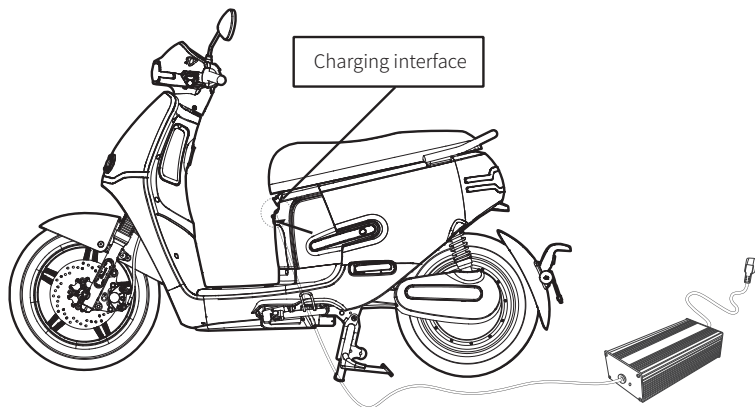

- Place the battery in the battery compartment and connect the vehicle plug to the battery.
- Then plug the charging plug of the charger into the charging interface above the footboard to charge the scooter.
- If the charging process does not start automatically, press the charging indicator button directly on the battery.

## Description of the battery charge level indicator on the battery

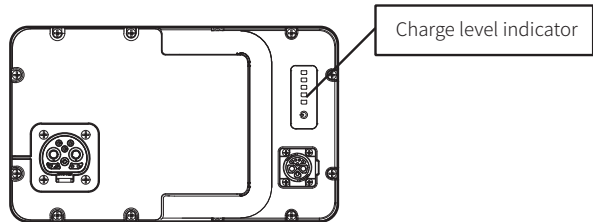

While charging, the charge level indicator shows the current battery charge level. Once the battery is fully charged, all LEDs light up continuously and no longer flash.

The current charge level is displayed by pressing the button next to the charge indicator - one LED corresponds to 20% charge level.

---

## Battery Manual

### Attention





Before using the battery, make sure that it is the original battery; do not use batteries from other manufacturers or of other types.

Check the battery for obvious external damage, leakage of liquid, overheating, expansion or other damage.

Due to self-consumption factors such as transport routes and storage times, the battery does not initially have maximum capacity. Charge the battery according to the charging instructions.

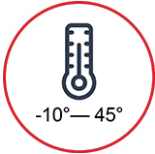
Batteries must not be disassembled and must be disposed of properly.

## Operating Environment

 <p>-10° — 45°</p>			
<p>Please use the battery between -10°C and 45°C.</p>	<p>Please prevent the battery from coming into contact with liquids, such as water, cleaning agents, etc.</p>	<p>Please avoid storing the battery near heat sources, open flames, flammable and explosive gases or liquids.</p>	<p>Please prevent metallic foreign objects from entering</p>

- At low temperatures, the available battery capacity decreases to varying degrees. For example: The available capacity is approx. 70% at -10 °C, 85% at 0 °C and up to 100% at 25 °C.
- If you notice any abnormalities, such as a strange odour, over heating or deformation, please stop using the battery immediately. Keep away from the battery and contact your specialist dealer immediately.
-  If the battery is dismantled or taken apart without authorisation, the manufacturer's warranty is automatically invalidated. Incorrect handling could cause the battery to overheat, start to smoke, catch fire or explode.

## Charging Environment

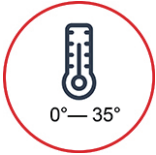
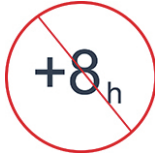
		
<p>Please use the original charger to charge the battery, and do not use other brand or type of charger to charge the battery.</p>	<p>Please charge the battery at the ambient temperature of 0°C~35°C</p>	<p>Please do not charge the battery for more than 8 hours, otherwise the service life of the battery will be affected.</p>

- In the early phase (0-80%), the charging speed is faster; in the later phase (80-100%), the charging speed is slower, because this process is configured for charging safety and is normal.
- In winter, when the outside ambient temperature drops below 0 °C, the charging process may stop, which is a normal condition. Please charge the battery at a suitable ambient temperature.
- At higher outside temperatures or shortly after the end of the ride, charging may not start immediately due to high temperatures inside the battery. It is recommended that the battery is left to rest for some time to lower the temperature.
- During charging, chargers have a thermal effect and the temperature of the housing may increase. Please avoid touching the charger during the charging process (possible risk of burns).

## Precautions for Using the Charger

- The charger should only be used indoors, under cover, or in environments protected from the weather.
  - It is strictly forbidden to use the charger in an environment with high temperatures, and the charger must not be placed in the seat shell during the charging process.
  - During charging, connect the battery first, then plug the charger into the power supply. After the battery is fully charged, disconnect the power supply before removing the charger from the battery port.
  - When the green indicator light on the charger lights up, end the charging process and disconnect the charger from the battery or the mains. Do not leave the charger connected to the power supply for an extended period when the battery is not charging.
  - If the indicator light on the charger is abnormal during the charging process, or if the charger smells strange or the housing of the charger is overheated, please stop charging immediately and contact your specialist dealer.
  - Please do not dismantle the charger yourself, and do not replace the charger components yourself.
  - If the charger is replaced, the new charger should match the battery model.
- 

## Storage Environment

- As soon as the battery is inserted into the vehicle and connected, energy is drawn from the battery for the alarm system or other consumers.
- Please store the battery in an environment between 0 °C-25 °C and not in an environment with a temperature higher than 40 °C; otherwise, the battery capacity will be irreversibly weakened.
- If the vehicle is not used for a longer period of time, the battery must be disconnected, stored separately, maintained and charged regularly, as otherwise the battery may be completely discharged and irreversibly damaged, e.g., deep discharge of the battery. In such a case, it is excluded from the warranty.

- If the battery is stored for a longer period of time, the most suitable battery charge level is 50-70%. If the battery charge level is less than 10% or more than 90%, the battery capacity will be irreversibly weakened.
- The following technical standards apply with regard to the self-consumption protection mode when the lithium battery is stored safely:
  - 1.If the battery is not used for a longer period of time, it can be stored in the vehicle (the battery plug is not disconnected), and the maximum safe storage period is 15 days; otherwise, the battery may become deeply discharged and the battery cannot be restored.
  - 2.If the battery is not used for a longer period of time, the charge level is not less than 50%, and the battery is stored separately or kept in the vehicle (the battery plug is disconnected), the maximum safe storage period is 2 months; otherwise, the battery may become deeply discharged and the battery cannot be restored.
- Please store the battery in a safe place; otherwise, the battery may be damaged in an uncontrolled manner: leakage, heating up, smoking, burning or explosion.



Undervoltage and deep discharge of the battery caused by improper use are not covered by the warranty.

---

## Precautionary measures when putting the battery into operation:

- When using the battery for the first time, please drain the battery as much as possible, then fully charge it before formally using it, so as to ensure that the actual capacity of the battery is as accurate as the electric quantity displayed on the instrument.
- In the later period, please keep the battery power at least 20% and charge the battery in time, so as to prolong the service life of the battery.
- When riding a motorcycle normally, it is recommended to control the speed at the middle speed. When starting the motorcycle, please slowly operate the throttle handle and gradually accelerate the motorcycle, thus extending the battery life.
- When the battery is used for many times, there will be a deviation between the actual capacity of the battery and the electric quantity displayed on the meter. Please charge and discharge the battery completely at regular intervals (no more than 3 months). The internal battery core and intelligent system can automatically calibrate the electric quantity of the battery, thus improving the experience effect.
- It is recommended to check the power plug of the battery every two months, and confirm whether the contact reed has the phenomena such as carbon deposition and oxidation (blackening). In case of these phenomena, please contact the dealer for maintenance.



The battery shall not be caught in the rain or flushed by water, and shall not be soaked in water. If the vehicle wades into the water, the water level shall not exceed the height of the battery compartment, otherwise the water will enter into the battery and the battery will be short circuited, thus causing the permanent battery failure. In this case, it is forbidden to charge the whole vehicle or battery again, otherwise the battery may be on fire, burned and exploded. Pls return the battery to your specialist dealer immediately for servicing.

## Driving instructions

### Precautionary measures before beginning your ride

If you are impaired due to the consumption of alcohol or drugs, driving is absolutely not recommended. Read the user manual. Ensure that you have fully understood all safety instructions, as well as all functions of the operating elements.

Please make sure of the following before you begin your ride:

- You are in good physical and mental health.
- You are wearing a helmet and other protective clothing.
- You should not operate the vehicle after consuming alcohol or taking medication.

### Protective Clothing

For safety consideration, we strongly recommend that you always wear qualified helmet, glasses, boots, trousers and long sleeves or jackets when driving.

## Riding training

Please spend time learning the HORWIN EK1 PRO's operation and controls, even if you have experience with other e-scooters. Practice riding in a safe area until you are comfortable with its size and weight. Enroll in a government-certified riding course—beginners should take basic training, while experienced riders can benefit from advanced courses.

## Pre-riding inspection

### General precautions

---

If you discover any damage, other abnormalities or technical faults when checking your vehicle, please rectify them immediately or have them rectified by an authorised specialist dealer.

Before using the scooter, check the following points to ensure your safety on the road:

- Function test of all switches of the left and right combination units
- Handle for speed control
- Recommended tyre pressure: Front wheel **200 - 225 kpa**, rear wheel **250- 280 kpa**
- Tyre surface for cracks, damage, wear or foreign objects adhering to the tyre
- Observe the legal tread depth (seasonal and country-specific deviations)
- Check if there is any error indicators light up in display
- Battery charge status
- Function test of headlight, tail light, brake light, indicators and horn
- Rear-view mirror (adjustment and cleanliness)
- Brake fluid level
- Brake system function test

## Loading Instructions

Overloading or improper loading can lead to irregular scooter operation. The exact dimensions and weight specifications can be found below in the technical data and dimensions.

The maximum capacity of EK1 PRO is 272KG, including weight of driver and passenger(s), as well as all components of the vehicle body. Your EK1 PRO shall be preferentially used for you and your passenger(s). However, if you want to load more goods, we suggest to use saddle bag. Please check with your dealer about the correct loading method and capacity range of EK1 PRO. Improper loading may affect the stability and maneuverability of EK1 PRO. Even if your EK1 PRO is correctly loaded, you should drive within safe speed range.

## Loading suggestions

1. Check tire pressure before loading
2. Adjust the way the goods are suspended if there is any abnormal load
3. Please ensure that all goods are securely fastened in case of any possible danger
4. Lower the center of gravity of the goods to keep it as close as possible to your own center of gravity.
5. Distribute the weight of the goods evenly on both sides of the scooter body.

# Starting the vehicle

The EK1 PRO can be started in 2 ways: with the mechanical key and APP online control

## I Method 1: Starting the vehicle with the mechanical key

- **Step 1:** Insert the key to turn the ignition lock to the start position and use it to start the vehicle.
- **Step 2:** Please fold up the side/centre stand, and press the “start switch” in the right-hand combi unit. The “READY” symbol appears on the display.
- **Step 3:** Lightly turn the throttle and enjoy your ride!

## I Method 2: APP online startup

- **Step 1:** After confirming that the vehicle app is successfully bound
  - **Step 2:** While making sure the vehicle is online, open the app homepage and slide the vehicle start button to start the vehicle
  - **Step 3:** Turn the throttle handle gently and enjoy your first riding.
-

# Method for binding the App to scooter

## Step 1: Download

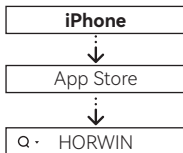

\*iOS: supports iOS 12.0 and above



\*Android 6.0 and above  
Phone memory at least 2GB

## Step 2: Register & Login

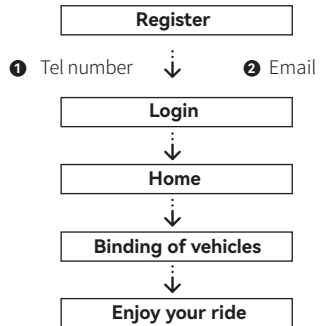

\* Binding need to fill in the vehicle VIN code, wait for the connection, click on the completion of the operation on the binding success!

## Braking instructions

- Check the brake handles before your ride.
- Excessive, sudden braking can cause the wheels to lock and skid, limiting control of the vehicle. In this case, release the brake lever and drive forwards continuously until control is restored, and then brake more gently.
- Slow down as much as possible, or come to a complete stop before turning. Avoid braking when cornering, as this can cause one or two wheels to slip, thereby reducing control of the scooter.
- When riding in wet, rainy conditions or on soft surfaces, the manoeuvrability and braking ability of the scooter are impaired. In this case, all your riding manoeuvres must be adjusted; sudden acceleration, braking or turning can lead to loss of control of the scooter.
- On long, steep, downhill stretches of road, excessive use of the braking system can lead to overheating and reduce the effectiveness of the braking power. Consequential damage can therefore not be ruled out.
- Ensure that your hands and feet are not resting on the brakes.

# EABS

EABS is braking energy recovery system, in the braking process, part of the energy generated by the motor operation is used for motor braking and the other part is fed back to the battery through the field effect drive power tubes in the controller, braking energy recovery not only improves the efficiency of the power source, but also reduces the burden on the braking system.

---

## TCS (Traction Control System)

Its function is to control the traction of the motorcycle through sensors to provide better stability and traction during acceleration or driving.

### **Main Functions**

1. When the wheels are idling, the motor power is controlled to reduce the tire slippage caused by the loss of tire traction by reducing the current output, which maintains the stability and control of the vehicle.
2. When the motorcycle accelerates sharply, it can help the vehicle control the power output better. When the motorcycle experiences tire slippage, the system reduces the power output of the electric motor to maintain traction and stability.
3. When encountering slippery road surfaces, it can reduce tire slippage and increase traction and stability.

## Switching off the vehicle

1

Fold down the side stand; the "READY" symbol will go out on the display, the electrical system of the entire vehicle is still in "Park" mode, and the vehicle will not move off when the throttle is opened.



2



2

Turn the key of the handlebar lock to position 2, and the electrical system of the entire vehicle will switch off.

## Trademarks and Legal Notices

“ ”、“HORWIN ”、“外” is a registered trademark held by Horwin Inc. Without the permission of the trademark owner, no one shall use the above trademark logo on the approved goods without permission.

Due to the continuous improvement of our products, design changes and other reasons, the product described in this manual may be inconsistent with the product you purchased. Please refer to the actual products.

---

## Maintenance Intervals

When a new vehicle reaches a range of 1000 km or service life of two months (whichever comes first), the first maintenance shall be carried out in the service center.

Regular maintenance for each 3000km or 6 months (whichever comes first) are recommended in the service center.

## Service Tips

Please switch off the vehicle and remove the battery before cleaning the vehicle. Do not clean your vehicle directly with a strong jet of water (e.g., high-pressure cleaner, etc.), which can cause faults or damage to mechanical and electrical components due to moisture.

Inspection Items	Mileage time interval (whichever comes first)			
	after the first 1000 km	every 3000 km	every year	every 2 years
Throttle grip Check for damage. If the wear limit is reached or if it is damaged, the component must be replaced.	√	√	√	√
Front/rear brake Check for damage If the wear limit is reached or if it is damaged, the component must be replaced.	√	√	√	√
Brake system Check for damage If the wear limit is reached or if it is damaged, the component must be replaced. Clean all components.	√	√	√	√

Inspection Items	Mileage time interval (whichever comes first)			
	after the first 1000 km	every 3000 km	every year	every 2 years
Replace the brake fluid (**)				√
Lights, Switch combinations Check for damage. If the wear limit is reached or if it is damaged, the component must be replaced. If necessary, the component must be adjusted.	√	√	√	√
Side stand and main stand Check for damage If the wear limit is reached or if it is damaged, the component must be replaced. Clean and lubricate all components.	√	√	√	√
shock absorber and linkage Front fork Check for damage If the wear limit is reached or if it is damaged, the component must be replaced. Clean all components.	√	√	√	√
Tight fit of all visible screws and nuts(*) Check for damage If the wear limit is reached or if it is damaged, the component must be replaced.	√	√	√	√

Inspection Items	Mileage time interval (whichever comes first)			
	after the first 1000 km	every 3000 km	every year	every 2 years
<p>Tires, Rims</p> <p>Check for damage</p> <p>If the wear limit is reached or if it is damaged, the component must be replaced.</p>	√	√	√	√
<p>Steering head bearing (* *)</p> <p>Check for damage</p> <p>If the wear limit is reached or if it is damaged, the component must be replaced.</p>	√	√	√	√
<p>Battery</p> <p>Check for damage</p> <p>If the wear limit is reached or if it is damaged, the component must be replaced.</p> <p>The batteries must be charged completely.</p>	√	√	√	√
<p>Motor (* *)</p> <p>Check for damage</p> <p>If the wear limit is reached or if it is damaged, the component must be replaced.</p>	√	√	√	√
<p><b>(*) Unless you have the appropriate tools, service data and mechanical qualifications, otherwise, the vehicle shall be inspected by your HORWIN authorized dealer.</b></p> <p><b>(* *) For safety reasons, we recommend that these items can only be provided by your authorized HORWIN dealer. The inspection intervals must be observed, otherwise there is no guarantee!</b></p>				

# Troubleshooting

Troubleshooting of the Whole Vehicle		
Phenomenon	Cause	Treatment Method
Turn on the power switch and the vehicle has no power output	The vehicle is not powered	Treatment Method 1 Check whether the connectors of the battery are plugged on the vehicle properly 2 The battery is under undervoltage condition, please charge the battery
Turn on the power switch, rotate the speed regulating handle, the motor is not started	<ol style="list-style-type: none"> <li>1. The vehicle is in a braking state</li> <li>2. The vehicle is in a parking state</li> <li>3. The side stand is not retracted</li> <li>4. The start switch has failure</li> <li>5. The braking handle is not reset</li> </ol>	<ol style="list-style-type: none"> <li>1. Check whether the vehicle is in a braking state</li> <li>2. Retract the side stand</li> <li>3. Contact the after sales service personnel and check the automatic switch</li> </ol>
The endurance mileage is insufficient	<ol style="list-style-type: none"> <li>1. The battery is not fully charged</li> <li>2. The tire pressure is insufficient</li> <li>3. The vehicle is braked and started frequently and the vehicle is overloaded</li> <li>4. The battery is aged or normally attenuated</li> <li>5. The environmental temperature is too low and the battery capacity is reduced</li> </ol>	<ol style="list-style-type: none"> <li>1. Check the charger for damage</li> <li>2. Check the tire pressure before each use</li> <li>3. Develop good driving habits</li> <li>4. Replace the battery</li> <li>5. Normal phenomenon</li> </ol>
The battery cannot be charged	<ol style="list-style-type: none"> <li>1. The charger plug is not inserted into the socket properly</li> <li>2. The battery temperature is excessively low</li> <li>3. The battery temperature is excessively high</li> </ol>	<ol style="list-style-type: none"> <li>1. Check whether the plug is loose</li> <li>2. Wait until the battery temperature is the charging temperature</li> <li>3. Contact the after-sales personnel to check the battery status</li> </ol>
The mobile phone cannot be charged through the USB interface	<ol style="list-style-type: none"> <li>1. USB cable plug is not plugged in the interface properly</li> <li>2. USB cable fails to meet the mobile standard</li> <li>3. The USB charger is damaged</li> </ol>	<ol style="list-style-type: none"> <li>1. Check whether the cable plug is plugged in the USB interface properly</li> <li>2. Please buy a connecting cable that meets the mobile standard</li> <li>3. Contact the after-sales service personnel. Replace damaged parts</li> </ol>

## Cleaning of the Vehicle



Please mix tap water and neutral detergent to clean the vehicle. After cleaning the vehicle, wipe the surface with a soft cloth.

Do not clean your vehicle directly with a strong jet of water (e.g., high-pressure cleaner, etc.), which can cause faults or damage to mechanical and electrical components due to moisture.

Wash your vehicle with cold fresh water immediately after driving on roads with high salt spray or near the sea. Do not use warm water, which accelerates the chemical reaction of salt. After drying the vehicle, apply anti-rust oil and anti-corrosion oil to the non-coated metal surface for protection. Please refer to the more detailed information and instructions in the separate service and maintenance manual.

## Secure storage of the vehicle

Please park the vehicle in a flat, solid, well-ventilated and dry place. Please avoid exposing the vehicle to weather conditions such as sunlight, rain/snow, etc. for long periods of time. If you park the vehicle for a longer period of time, please note the additional information in the service/maintenance booklet.

## Basic Parameter

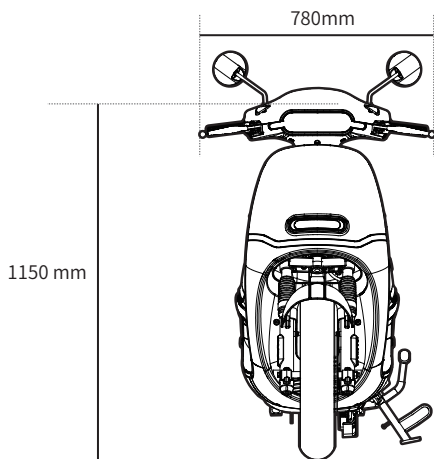
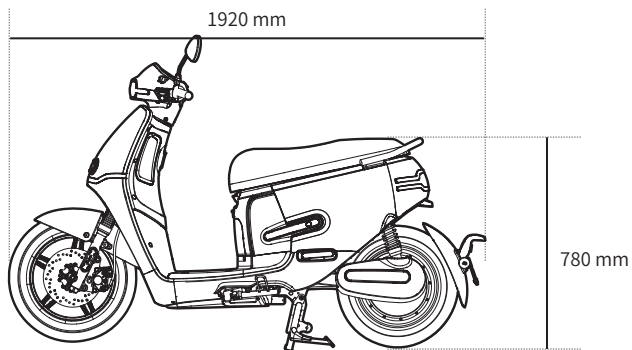

## PERFORMANCE

<b>Top Speed</b>	45km/h
<b>Range</b>	97km (with 40 kph)

## DIMENSION

<b>L*W*H</b>	1920mm*720mm *1150mm
<b>Saddle Height</b>	780mm
<b>Ground Clearance</b>	132mm
<b>Wheelbase</b>	1290mm
<b>Weight(G.W)</b>	≤96.8kg (without battery)

## POWERTRAIN

<b>Motor</b>	Hub Motor
<b>Controller</b>	FOC
<b>Max Power</b>	3.0kW
<b>Continue Rated Power</b>	2.0kW
<b>Battery</b>	72V, 36Ah (optional with second battery)
<b>Charging Time (10A)</b>	≈4.5h
<b>Ride Mode</b>	1/2/3/R

## CHASSIS

<b>Brake System</b>	Disc Brake	
<b>Wheels</b>	Tire	100/80 R14
		110/70 R13
	Rim	Aluminium Alloy

## SMART&FEATURES

<b>Safety System</b>	GPS+Transaction Alarm
<b>APP &amp; IOT</b>	●
<b>All-around LED Lights</b>	●

## ACCESSORY: TAILSTOCK、BAG PACK、RACKER

\* The endurance of the product is related to load bearing, temperature, speed, road surface and other factors.

# Warranty Registration Form

<b>Year:</b>		<b>Model:</b>	
VIN No.:			
Motor No.:			
Date of purchase:			
User name:			
User Address:			
User Contact number:			

Note: This form shall be completed by the customer and shall be filed by the dealer.

## Policy of Warranty

Thank you very much for purchasing EK1 PRO electric motorcycle produced by HORWIN. In order to provide users with comprehensive service guarantee, according to relevant laws and regulations and relevant national regulations on after-sales service, and in combination with product characteristics, the specific provisions about the after-sales service are as follows:

Of the whole vehicle are guaranteed for two years or a total mileage of 20,000 kilometers, whichever comes first, and the Warranty Standard below is the implementation basis is the implementation basis.

Within the warranty period, HORWIN service provider will freely provide repair service and replacement service. If the maintenance is beyond the service period or scope of "Warranty Standard", HORWIN service provider will provide paid services according to local market conditions and maintenance prices. For the sold products, the warranty period starts from the date of signature for express delivery.

# Warranty Standards

Parts Name	Warranty Standard	Warranty Exemption	Warranty Period
<b>Lithium battery pack</b>	The company provides warranty for lithium batteries after being fully charged in the specified use environment and are not subject to external force impact and have abnormal voltage, cannot be charged, and have less than 70% capacity .And the warranty period for replaced battery is calculated base on the remaining date of warranty period of the original battery).	1. Self-disassembly of the battery pack may cause damage to the internal battery cell connection (because of the complex internal battery pack cell connection, it is not recommended that the user disassemble the battery pack)	24 months or 20,000 km, whichever comes first
		2. Damages caused by failure to comply with battery storage, protection, maintenance requirements. e.g. The battery is under-voltage or cell down caused by long-term non-use of the vehicle or failure to charge in time.	
<b>Motor</b>	Quality problems which cannot be repaired like open phase or burn-out of coil, demagnetization or loss of magnetic steel and so on.	1.Damage to internal circuit of motor caused by unauthorized dis-assembly	24 months or 20,000 km, whichever comes first
		2. Motor damage caused by human factors.	
<b>Frame</b>	1. Loss weld, incomplete and missing welding of the weld joints	1. Damage caused by human factors or improper use	24 months or 20,000 km, whichever comes first
	2.Cracks in key area, or frame fracture.	2.Unauthorized modifications of frame structure	
	3. Failure to apply license plate due to the unclear VIN code.	3. Unauthorized modifications of body structure	

Parts Name	Warranty Standard	Warranty Exemption	Warranty Period
<b>Display</b>	1.No display or incomplete display of the LCD panel.	Scratches or damage to instrument from human factors	24 months or 20,000 km whichever comes first
	2.Inaccurate digit of the LCD panel.		
	3. Date shows abnormally.		
<b>Charger</b>	1. Charge failure caused by Charging harness defect.	1. Modifications of internal structure or wire.	24 months
	2. The indicator doesn't turn to red.	2. No fault after testing	
<b>Converter</b>	1.Internal damage, or voltage regulation failure	No fault after testing	24 months or 20,000 km whichever comes first
	2. No DC output, or over-voltage.		
<b>Controller</b>	Due to product reasons,the performance failure or quality problem occurs and cannot repaired	Damage resulting from unauthorized modifications of the internal circuit or structure of the controller	24 months or 20,000 km whichever comes first

Parts Name	Warranty Standard	Warranty Exemption	Warranty Period
<b>Main Cable</b>	1. During proper use, problems like short circuit, open circuit, ablation and other problems, etc. that cannot be repaired occurs (caused by the caused by defects in the main cable).	1. Unauthorized modifications of the circuit or damage caused by human factors.	24 months or 20,000 km whichever comes first
	2. Circuit defects not caused by improper installation	2. Tearing or abrasion in cable surface (not structural problem)	
<b>Center Control</b>	1. Communication fault	1. Damage caused by unauthorized repairs.	24 months or 20,000 km whichever comes first
	2. Port output fault	2. Unauthorized modifications	
	3. Phonetic function fault	3. Improper operation or use	
	4. Remote key fault.	4. Damage caused by abnormal environment.	
	5. System halt	5. Damage caused by human factors or irresistible natural disasters.	
<b>Steering Column</b>	1. The weld between the steering column riser and the upper connecting plate is loose.	Deformation or damage caused by human factors or improper use.	24 months or 20,000 km whichever comes first
	2. Crack, fracture		
<b>Rear Fork</b>	Fracture, loose weld	1. Damage caused by human factors or improper use.	24 months or 20,000 km whichever comes first
		2. Damages caused by modifications.	

Parts Name	Warranty Standard	Warranty Exemption	Warranty Period
<b>Shock Absorber</b>	1. The front shock absorber is in normal use, and the lower base cylinder fork tube is broken	1. Oil leakage caused by significant damage due to improper use	24 months or 20,000 km whichever comes first
	2. Serious oil leakage in the oil seal area.	2. The parts have been replaced, removed and cannot be restored	
	3. The rear shock absorber is leaking oil and the joint is desoldering.	3. Obvious bumps of shock absorber (Sensory factors)	
	4. The piston rod of the rear shock absorber damper is broken.	4. Soft or hard shock absorber (Sensory factors)	
		5. Rod deflection of rear shock absorber caused by modification or overload	
<b>Wheel Hub</b>	1. wheel hub/rim peeling or breaking	1. Wheel hub deformation and scratches or damage caused by improper maintenance and overload	24 months or 20,000 km whichever comes first
	2. Quality problems of front wheel hub that cause the brake disc stuck and fail to rotate	2. Deformation caused by collision	
	3. Fracture of wheel hub		
	4. Deformation of the hub or wheel		
<b>Rear Armrest</b>	1. Rust of plating layer	1. Damage caused by improper use, scratches, collision or overload.	24 months or 20,000 km whichever comes first
	2. Plating layer detachment, fracture	2. Deformation caused by collision	
<b>Horn</b>	Malfunction caused by structure and quality problems	No errors after testing	24 months or 20,000 km whichever comes first

Parts Name	Warranty Standard	Warranty Exemption	Warranty Period
<b>Lock Set</b>	1. The front lock failure	1. Lock set was broken caused by human factor	24 months or 20,000 km whichever comes first
	2. Battery lock failure	2.Damages caused by improper use.	
	3. Remote control failure		
<b>Brake System</b>	1. Breakage or falling off due to material problems	1. Improper disassembly of the hydraulic disc brake upper and lower pump assemblies leads to oil leakage	24 months or 20,000 km whichever comes first
	2. Brake failure of hydraulic braking system caused by leakage of gas, air resistance, decreased pump pressure, or brake caliper seizing	2. Malfunction of hydraulic disc brake caused by lack of oil instead of damage	Brake disc and brake pads and brake oil are not included
	3. Brake uninterrupted and cannot be repaired	3. Worn-out of brake disc	
		4. Brake system damage caused by self-modification	
<b>Throttle</b>	Unable to adjust speed due to circuit and structural problems	Abnormal throttle caused by improper use	24 months or 20,000 km whichever comes first
<b>Headlight</b>	Malfunction caused by quality problems.	Damage caused by unauthorized circuit modification.	24months or 20,000 km whichever comes first
<b>Taillight</b>			
<b>Turn Signal</b>			
<b>Rear License Light</b>			
<b>Left/right Switch Assembly</b>	1. Switch failure, failure to be seat or reset	1.Unauthorized circuit modifications	24 months or 20,000 km whichever comes first
	2. Loose and breakage of switch button because of the quality problems	2. Missing pieces or inconsistency	
	3. Short circuit, open circuit or poor contact inside switch		
	4. Inconsistent switch circuit		

Parts Name	Warranty Standard	Warranty Exemption	Warranty Period
<b>Side Stand</b>	Fracture or loose weld	1. Deformation or damage caused by human factors or improper use	24 months or 20,000 km whichever comes first
		2. Scratches or damage to surfaces caused by human factors	
		3. Self-modification or self-repair such as welding, etc	
<b>Seat Cushion</b>	Bursting or cracking caused by quality problem	Breakage and fracture of the cushion surface caused by human factors	24 months
<b>Exterior Plastic Parts</b>	If the area of peeling or crack that caused by the paint problem is more than 1 CM <sup>2</sup> , the part can be replaced	Damage caused by human factors	24 months
<b>Tire</b>	Cracking, swelling or bursting	1. Normal wearing	6 months
		2. Damage caused by human factors	
		3. External damage	
<b>Vulnerable parts</b>	Non-warranty parts: bulbs, brake pads, brake fluid, rear mirrors, power sockets, in-haul cables, USB port , PP parts, screws, nuts and other standard parts, decorative parts, fuses, chains, vulnerable and consumable parts.	No warranty	

## Instructions to other items not covered by warranty standard

Based on the above table, if the items are beyond the time limit and scope of warranty, they are beyond the scope of warranty service.

- Other parts not included in the above table, such as brake shoe, brake oil, power socket, cable, USB, PP and appearance parts, are vulnerable and consumable parts and cannot be covered by the "warranty" service.
- Normal maintenance services, including but not limited to: replacing gear oil, checking tires, checking brakes, adjusting brakes, changing brake fluid, checking electrical system, checking chain tension, adjusting chain tension, replacing chains and checking battery packs, are not within the scope of "warranty".
- Advertising promotion items, gift items, sound volume, touch-sense items and other sensory & cognitive items.
- Damage caused by smoke, earthquake, typhoon, flood, fire, lightning strike, chemical corrosion and other force majeure factors.
- If the vehicle is not repaired by the service provider, the parts are modified, decomposed and damaged by the user, other parts are damaged due to use of non-original parts, and the circuit and configuration are modified by the user without authorization, the user will not be covered by the warranty service.
- Damage caused by human factors such as crash, falling, overspeed, overload, unauthorized modification, failure to use original parts, failure to operate the vehicle according to operating instructions.
- There is no invoice, warranty card or bill or the bill is inconsistent with the card.
- If the parts such as controller and charger are provided with trademarks or seals, and the trademarks or seals are torn artificially, these parts will not be covered by guaranteed.
- The user fails to use and maintain the battery normally, the storage time exceeded 2 months (the battery is plugged into the vehicle and stored for more than 15 days; the initial power is less than 50% and the battery is stored separately for more than 2 months), and the battery is not charged in time, therefore the battery feeding and undervoltage are caused and the faults are irreparable.

# Repair & Maintenance Records

In order to enhance your warranty experience, please be sure to repair and maintain your vehicle at our authorized dealers. And please record in the form below and stamp the dealer's seal.

<b>Model:</b>	<b>Frame No.:</b>	<b>Motor No.:</b>
The 1st service		Dealer's stamp
Date:		
Range:		
The 2nd service		Dealer's stamp
Date:		
Range:		
The 3rd service		Dealer's stamp
Date:		
Range:		
The 4th service		Dealer's stamp
Date:		
Range:		
The 5th service		Dealer's stamp
Date:		
Range:		
The 6th service		Dealer's stamp
Date:		
Range:		

The 7th service	
Date:	
Range:	Dealer's stamp
The 8th service	
Date:	
Range:	Dealer's stamp
The 9th service	
Date:	
Range:	Dealer's stamp
The 10th service	
Date:	
Range:	Dealer's stamp
The 11th service	
Date:	
Range:	Dealer's stamp
The 12th service	
Date:	
Range:	Dealer's stamp
The 13th service	
Date:	
Range:	Dealer's stamp
The 14th service	
Date:	
Range:	Dealer's stamp

The 15th service	
Date:	
Range:	
The 16th service	Dealer's stamp
Date:	
Range:	
The 17th service	Dealer's stamp
Date:	
Range:	
The 18th service	Dealer's stamp
Date:	
Range:	
The 19th service	Dealer's stamp
Date:	
Range:	
The 20th service	Dealer's stamp
Date:	
Range:	

# HORWIN

## **HORWIN Headquarter**

Building 1 | No.5 Chuangzhi Road | Tianning District

Changzhou | Jiangsu | China

Phone.: +86 400-778-6688 | Email: horwin@horwinglobal.com

[www.horwin.com](http://www.horwin.com)

