

HORWIN

Please do not use Vehicle before you read this manual carefully and know function of it.
Please keep this manual carefully.

SK3 PLUS USER MANUAL



www.horwin.com

SK3 PLUS User Manual

Welcome to the HORWIN family!

We will help you to use the SK3 PLUS e-scooter correctly and safely. To ensure your safety, please read this manual carefully before using the e-scooter for the first time, and make sure that you always meet the following requirements:

Fully understand the information in this manual, including the precautions and warnings.

HORWIN accepts no liability arising from unauthorised modifications, the use of replicas, or the installation of components that impair the performance and safety of the e-scooter.

Please contact the HORWIN Customer Service Centre at this e-mail address:

service@horwinglobal.com

If you should have a problem with this scooter, we will be happy to help you.

We wish you a safe and pleasant ride!

Safety Instructions

Please read this product manual carefully, and only use this vehicle if you are mentally and physically fit to do so.

Please follow the traffic rules, do not deliberately drive in reverse for long distances, do not run red lights, and do not use mobile phones while driving.

Please do not use any third-party accessories, and do not disassemble or modify the e-scooter without authorisation; otherwise, any resulting damage will be at your expense, and you will lose the right to make use of our warranty service.

Due to the continuous improvement of the product, the vehicle you purchase may differ slightly from the vehicle described in this manual. If you are unsure about the use, repair and commissioning of this vehicle, please contact our authorised specialist dealers.

 Please read the following instructions carefully for your own safety and that of others:

- Before riding the e-scooter, check that all safety-relevant functions (e.g., lighting system, horn, braking system, etc.) are in working order in order to ensure road safety. If you should notice any problems, please contact your specialist dealer immediately.

- To ensure your safety, wear a safety helmet, gloves and appropriate protective equipment when driving.
 - Please make sure that you are in good health and not tired. Please do not ride your scooter if you have consumed drugs, medication, alcohol or impairing substances.
 - Please observe the traffic regulations and adjust your speed according to the weather and road conditions.
 - Do not park the vehicle in unauthorised locations (e.g., in escape routes, fire brigade access roads, restricted areas, etc.)
 - We do not recommend charging or parking the electric scooter in the immediate vicinity of flammable materials. Charging should always be done under supervision.
-

Product Overview

Schematic representation of the vehicle

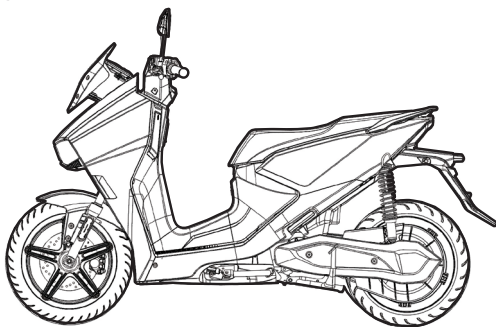

Description of Parts

Left Side

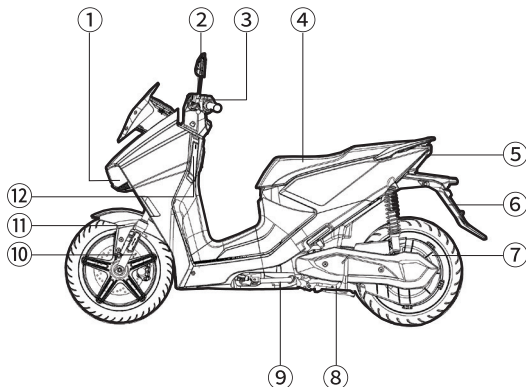

- ① Headlight
- ② Rearview mirror
- ③ Left combination switch
- ④ Seat
- ⑤ Tail light
- ⑥ Rear fender
- ⑦ Belt protection cover
- ⑧ Middle stand
- ⑨ Side stand
- ⑩ Front shock absorber
- ⑪ Front fender
- ⑫ Storage compartment
(built-in USB charging socket, max. consumption 1 A, voltage 5 V DC)

Right Side

- ① Throttle
- ② Right combination switch
- ③ Ignition lock
- ④ Footboard
- ⑤ Rear armrest
- ⑥ Reflector
- ⑦ Rear shock absorber
- ⑧ Cover of the rear swingarm
- ⑨ Wheel speed sensor

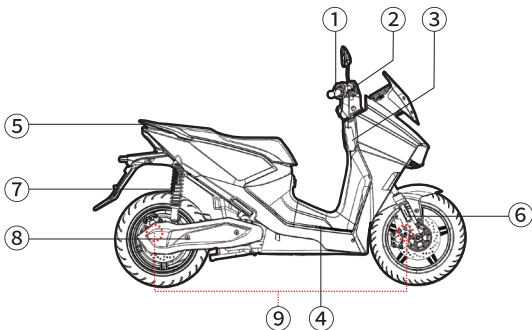

Instrument and Combination Switch

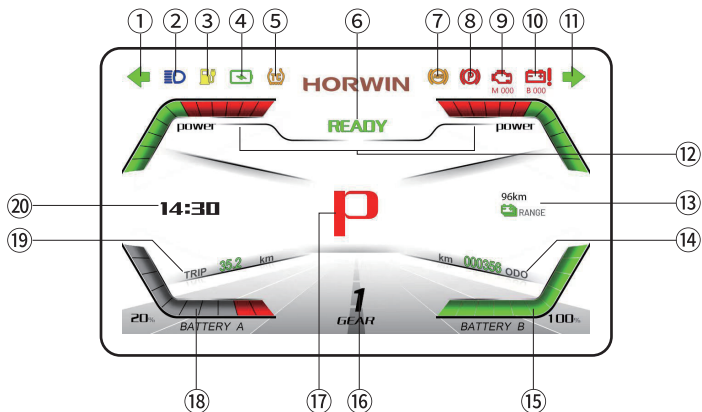

①. Indicator, left

This indicator light flashes when you press the left indicator.

②. High beam indicator lamp

This indicator lights up when the high beam is switched on.

③. Low battery indicator

When the power is less than 10%, the indicator lights up.

④. Kinetic energy recovery

The motor recovers power when the vehicle decelerates and the indicator light comes on.

⑤. Indicator light for TCS

When the vehicle skids, the vehicle automatically switches on the TCS braking system and the indicator light comes on.

⑥. Operational indication

Indicates that the vehicle has entered a state ready to ride. Rotate the speed control handle to move the vehicle forward.

⑦. Indicator light for ABS

When the vehicle is braking in an emergency, the vehicle automatically activates the ABS braking system and the indicator light comes on.

⑧. Brake light

The indicator light comes on when the vehicle brakes smoothly.

⑨. Motor warning light

The indicator light comes on when the vehicle motor fails.

⑩. Rechargeable battery warning light

The indicator light comes on when the vehicle battery fails.

11. Indicator, right

This indicator light flashes when you press the right indicator.

12. Power consumption

13. Range

Display range

14. Total mileage

Display of the total mileage reading.

15. Battery B Indicator

Displays the current battery charge level as a percentage.

16. Gear display

Displays the currently selected riding mode.

- The maximum speed in the 1st riding mode is up to 50 km/h
- The maximum speed in the 2nd riding mode is up to 75 km/h
- The maximum speed in the 3rd riding mode is up to 100 km/h

17. Speed per hour

Displays the current speed.

18. Battery A Indicator

Displays the current battery charge level as a percentage.

19. Trip odometer

Display of the current distance travelled (automatic reset after restart).

20. Trip travel time display

Display of the current trip travel time (automatic reset after restart).

Combination switch

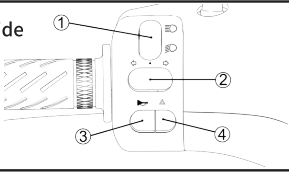
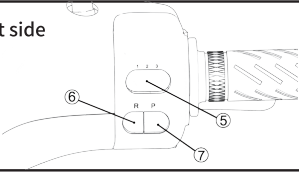
Left side 	Right side 
<p>① Left-hand combination switch with high beam and dipped beam</p> <ul style="list-style-type: none">• Press the switch upwards to switch on the high beam.• Press the switch down to switch on the dipped beam.	<p>⑤ Right-hand combination switch with riding mode selector</p> <ul style="list-style-type: none">• Left position: 1. riding mode• Centre position: 2. riding mode• Right position: 3. riding mode
<p>② Indicato</p> <ul style="list-style-type: none">• Press the switch to the left to switch on the left indicator.• Press the switch to the right to switch on the right indicator.• Move the switch to the centre position to switch off the indicator.	<p>⑥ Reverse switch</p> <ul style="list-style-type: none">• Press and hold the button to activate reverse mode.
<p>③ Horn</p> <ul style="list-style-type: none">• Press the horn button to sound the horn signal.• The horn signal ends when the horn button is released.	<p>⑦ Start switch</p> <ul style="list-style-type: none">• Press the button to switch to standby/READY mode.
<p>④ Hazard warning lights</p> <ul style="list-style-type: none">• Press the button to activate the hazard warning lights.• Press the button again to deactivate the hazard warning lights.	

Vehicle lock and radio remote control

Radio remote control

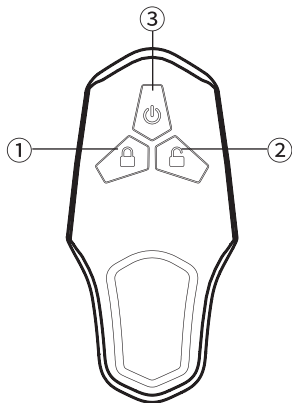

① Activation of the alarm system

Pressing the button activates the acoustic alarm system. If the radio remote control is more than approx. 2 metres away from the scooter, the alarm system activates itself automatically after a certain period of time.

② Deactivation of the alarm system

Pressing the button deactivates the acoustic alarm system.

③ Power button

The vehicle can be switched on by pressing the button twice. (Pressing button '2' switches the vehicle off.)

Please note that the batteries in the radio remote controls must be replaced after a certain time, and when the radio remote controls do not work.

Mechanical Key

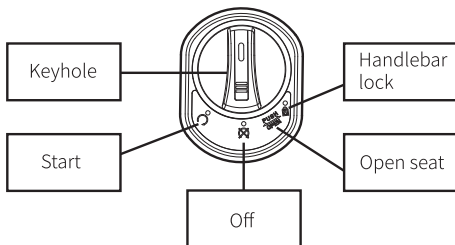
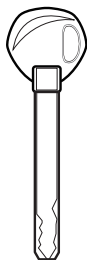

Starting the scooter

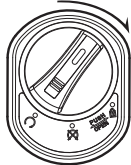

Open seat



Handlebar lock

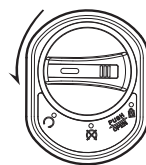

Switching the scooter on and off

Insert the mechanical key and turn it to the "Start" position to switch on the vehicle. Turn the key back to the "Off" position to switch off the vehicle.

Opening the seat

Insert the mechanical key and turn it to the "Open seat" position to unlock the seat. If the radio remote control is less than approx. 2 metres away, the seat can be opened by pressing it and turning it to the left.

*assuming the radio remote control and alarm system are working correctly.

Handlebar lock

Turn the handlebars to the furthest left position. The handlebars are locked by pressing and turning the key anti-clockwise to the "handlebar lock" position.

Battery and Charger

Instructions for using batteries

The vehicle has two charging modes: battery charging and body charging.
External charging mode

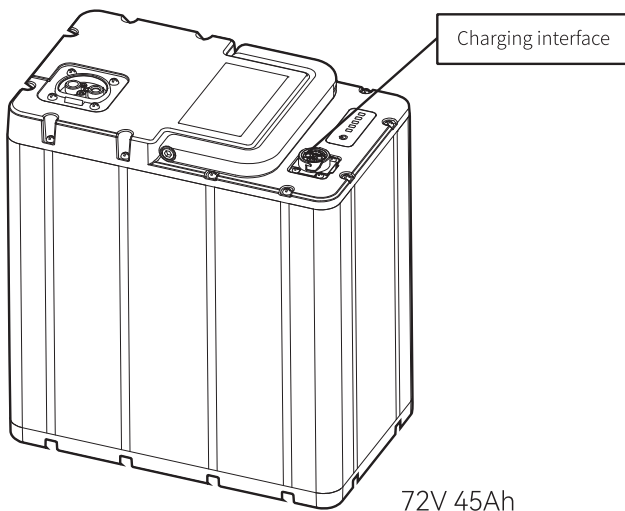

First connect the charger to the battery interface, and then to the socket. If the charging process does not start automatically, press the charging indicator button.

In-vehicle charging mode

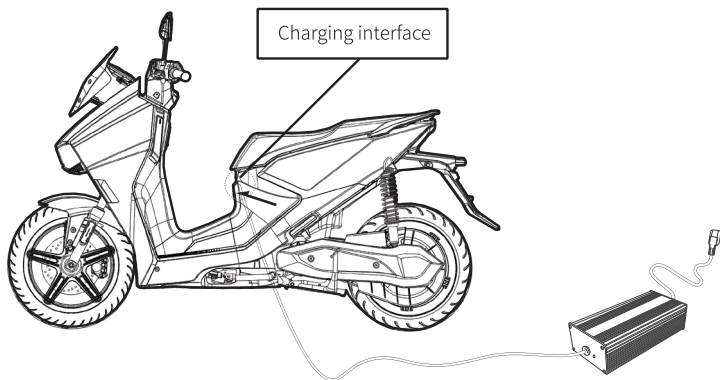

- Place the battery in the battery compartment and connect the vehicle plug to the battery.
- Then plug the charging plug of the charger into the charging interface above the footboard to charge the scooter.
- If the charging process does not start automatically, press the charging indicator button directly on the battery.

Description of the battery charge level indicator on the battery

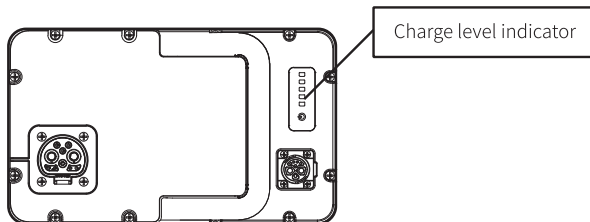

While charging, the charge level indicator shows the current battery charge level. Once the battery is fully charged, all LEDs light up continuously and no longer flash.

The current charge level is displayed by pressing the button next to the charge indicator - one LED corresponds to 20% charge level.

Battery Manual

Before using the battery, make sure that it is the original battery; do not use batteries from other manufacturers or of other types.





Check the battery for obvious external damage, leakage of liquid, overheating, expansion or other damage.

Due to self-consumption factors such as transport routes and storage times, the battery does not initially have maximum capacity.

Charge the battery according to the charging instructions.

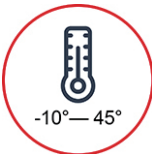
Batteries must not be disassembled and must be disposed of properly.

Operating Environment

 <p>-10° — 45°</p>			
<p>Please use the battery between -10°C and 45°C.</p>	<p>Please prevent the battery from coming into contact with liquids, such as water, cleaning agents, etc.</p>	<p>Please avoid storing the battery near heat sources, open flames, flammable and explosive gases or liquids.</p>	<p>Please prevent metallic foreign objects from entering</p>

- At low temperatures, the available battery capacity decreases to varying degrees. For example: The available capacity is approx. 70% at -10 °C, 85% at 0 °C and up to 100% at 25 °C.
- If you notice any abnormalities, such as a strange odour, over heating or deformation, please stop using the battery immediately. Keep away from the battery and contact your specialist dealer immediately.
-  If the battery is dismantled or taken apart without authorisation, the manufacturer's warranty is automatically invalidated. Incorrect handling could cause the battery to overheat, start to smoke, catch fire or explode.

Charging Environment

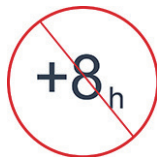
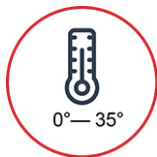

Please use the original charger to charge the battery, and do not use other brand or type of charger to charge the battery.

Please charge the battery at the ambient temperature of 0°C~35°C

Please do not charge the battery for more than 8 hours, otherwise the service life of the battery will be affected.

- In the early phase (0-80%), the charging speed is faster; in the later phase (80-100%), the charging-speed is slower, because this process is configured for charging safety and is normal.
- In winter, when the outside ambient temperature drops below 0 °C, the charging process may stop, which is a normal condition. Please charge the battery at a suitable ambient temperature.
- At higher outside temperatures or shortly after the end of the ride, charging may not start immediately due to high temperatures inside the battery. It is recommended that the battery is left to rest for some time to lower the temperature.
- During charging, chargers have a thermal effect and the temperature of the housing may increase. Please avoid touching the charger during the charging process (possible risk of burns).

Precautions for Using the Charger

- The charger should only be used indoors, under cover, or in environments protected from the weather.
 - It is strictly forbidden to use the charger in an environment with high temperatures, and the charger must not be placed in the seat shell during the charging process.
 - When the green indicator light on the charger lights up, end the charging process and disconnect the charger from the battery or the mains.
 - If the indicator light on the charger is abnormal during the charging process, or if the charger smells strange or the housing of the charger is overheated, please stop charging immediately and contact your specialist dealer.
 - Please do not dismantle the charger yourself, and do not replace the charger components yourself.
 - If the charger is replaced, the new charger should match the battery model.
-

Storage Environment

- As soon as the battery is inserted into the vehicle and connected, energy is drawn from the battery for the alarm system or other consumers.
- Please store the battery in an environment between 0 °C-25 °C and not in an environment with a temperature higher than 40 °C; otherwise, the battery capacity will be irreversibly weakened.
- If the vehicle is not used for a longer period of time, the battery must be disconnected, stored separately, maintained and charged regularly, as otherwise the battery may be completely discharged and irreversibly damaged, e.g., deep discharge of the battery. In such a case, it is excluded from the warranty.

■ If the battery is stored for a longer period of time, the most suitable battery charge level is 50-70%. If the battery charge level is less than 10% or more than 90%, the battery capacity will be irreversibly weakened.

■ The following technical standards apply with regard to the self-consumption protection mode when the lithium battery is stored safely:



1.If the battery is not used for a longer period of time, it can be stored in the vehicle (the battery plug is not disconnected), and the maximum safe storage period is 15 days; otherwise, the battery may become deeply discharged and the battery cannot be restored.

2.If the battery is not used for a longer period of time, the charge level is not less than 50%, and the battery is stored separately or kept in the vehicle (the battery plug is disconnected), the maximum safe storage period is 2 months; otherwise, the battery may become deeply discharged and the battery cannot be restored.

■ Please store the battery in a safe place; otherwise, the battery may be damaged in an uncontrolled manner: leakage, heating up, smoking, burning or explosion.

■ Undervoltage and deep discharge of the battery caused by improper use are not covered by the warranty.

Precautionary measures when putting the battery into operation:

- When using the battery for the first time, please drain the battery as much as possible, then fully charge it before formally using it, so as to ensure that the actual capacity of the battery is as accurate as the electric quantity displayed on the instrument.
- In the later period, please keep the battery power at least 20% and charge the battery in time, so as to prolong the service life of the battery.
- When riding a motorcycle normally, it is recommended to control the speed at the middle speed. When starting the motorcycle, please slowly operate the throttle handle and gradually accelerate the motorcycle, thus extending the battery life.
- When the battery is used for many times, there will be a deviation between the actual capacity of the battery and the electric quantity displayed on the meter. Please charge and discharge the battery completely at regular intervals (no more than 3 months). The internal battery core and intelligent system can automatically calibrate the electric quantity of the battery, thus improving the experience effect.
- It is recommended to check the power plug of the battery every two months, and confirm whether the contact reed has the phenomena such as carbon deposition and oxidation (blackening). In case of these phenomena, please contact the dealer for maintenance.



The battery shall not be caught in the rain or flushed by water, and shall not be soaked in water. If the vehicle wades into the water, the water level shall not exceed the height of the battery compartment, otherwise the water will enter into the battery and the battery will be short circuited, thus causing the permanent battery failure. In this case, it is forbidden to charge the whole vehicle or battery again, otherwise the battery may be on fire, burned and exploded. Please transfer the battery to the dealer for maintenance immediately.

Riding Guide

Precautions for Preparation

Drinking is a direct cause of death in motorcycle driving. Every year, 50% of drivers die from driving after drinking. Do not drive after drinking

Before your first drive, we strongly request you to:

Read the user manual;

Confirm that you have fully understood all safety information;

Understand how all control accessories work;

Before your first drive, please confirm that you:

Are in good physical and psychological conditions;

Wear helmet (fasten connecting shackle of the helmet and the safety belt), glasses and other protective clothing;

Do not drive after drinking or taking medicines;

Protective Clothing

For safety consideration, we strongly recommend that you always wear qualified helmet, glasses, boots, trousers and long sleeves or jackets when driving.

Warnings

In a collision, not wearing a helmet may increase the risk of injury or death. Please make sure to wear helmet, glasses and other protective equipment at all times when driving.

Driver Training

It's necessary to improve your driving skills. Even if you have the experience of riding other motorcycles before, you still need to take time to get familiar with the working principle and driving control of SK3 PLUS. Please practice driving the motorcycle in a safe place until your skills are mature and you have got used to the size and weight of SK3 PLUS.

We request all drivers to take driving courses certified by local government. New drivers should attend basic training, even experienced drivers can benefit from advanced courses.

Inspection before riding

Cautions

When inspecting SK3 PLUS, should you find any damage or problem, please correct it or have it corrected with assistance from authorized dealer before riding.

Before riding the SK3 PLUS electric motorcycle, please check the following items to ensure your safety on road.

Whether the handle rotates stably and flexibly.

Can left/right handle switch work normally.

Can the speed control handle work normally.

Ensure normal pressure of tire. Suggested tire pressure: 175 kPa for front wheel and 225 kPa for rear wheel.

Check the tire surface for fracture, damage, wear or foreign matter piercing or adhesion.

Whether the tread depth is sufficient (> 0.8mm).

Is there any fault alarm lamp on the instrument panel on.

Is the battery fully charged.

Can the headlamp, tail lamp, stop lamp and turn signal lamps work normally.

Can the horn work normally.

Are rearview mirrors clean. Adjust them to proper angle.

Is the brake oil sufficient. Can handles and brake system work normally.

Should there be any abnormality or operation issue, please contact HORWIN customer service center.

Email: service@horwinglobal.com

Restrictions and Guidelines on Roads

General Information

Cautions

Overloading or improper loading may lead to abnormal motorcycle operation, which may cause serious injury or death. Please follow all load limits and other loading information in this manual.

Loading Instructions

The maximum capacity of SK3 PLUS is 292KG, including weight of driver and passenger(s), as well as all components of the vehicle body. Your SK3 PLUS shall be preferentially used for you and your passenger(s). However, if you want to load more goods, we suggest to use saddle bag. Please check with your dealer about the correct loading method and capacity range of SK3 PLUS. Improper loading may affect the stability and maneuverability of SK3 PLUS. Even if your SK3 PLUS is correctly loaded, you should drive within safe speed range.

When loading goods, please following the following rules:

Check whether the two tires are properly charged;

If you change your normal load, you may need to adjust the way the goods are hung;

To prevent goods from loosening which may cause hidden danger, please ensure that all goods are firmly bound;

Lower the center of gravity of goods and make it as close as possible to your own center of gravity;

Distribute the weight of goods evenly on two sides of the vehicle body;

Methods for starting the vehicle

The SK3 PLUS can be started in three ways: with the mechanical key, with the keyless “go” function, and with the APP online startup.

I Method 1: Starting the vehicle with the mechanical key

- **Step 1:** Insert the key to turn the ignition lock to the start position and use it to start the vehicle.
- **Step 2:** Please fold up the side/centre stand, and press the “start switch” in the right-hand combi unit. The “READY” symbol appears on the display.
- **Step 3:** Lightly turn the throttle and enjoy your ride!

I Method 2: Starting the vehicle with the keyless “go” function

- **Step 1:** The distance between the radio remote control and the vehicle must be less than approx. 2 metres.
- **Step 2:** Fold up the side/centre stand. Press the ignition lock for approx. 1 second. The edge of the ignition lock will start to light up. Then turn the ignition switch to the “Start” position, and the vehicle will switch on. Press the “start switch” on the right-hand combi unit; the “READY” symbol will appear on the display.
- **Step 3:** Turn the throttle slightly and enjoy your ride!

I Method 3: APP online startup

- **Step 1:** After confirming that the vehicle app is successfully bound
 - **Step 2:** While making sure the vehicle is online, open the app homepage and slide the vehicle start button to start the vehicle
 - **Step 3:** Turn the throttle handle gently and enjoy your first riding.
-

About the method of vehicle binding app

Step 1: Download

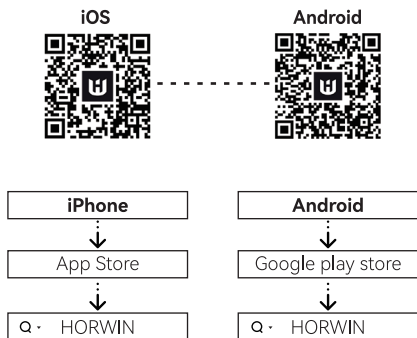

*iOS: supports iOS 12.0 and above

*Android 6.0 and above
Phone memory at least 2GB

Step 2: Register & Login

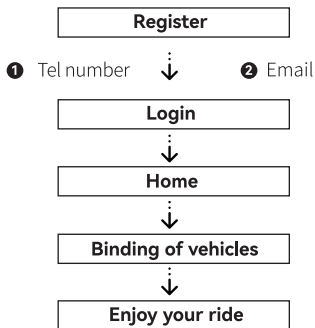

* Binding need to fill in the vehicle VIN code, wait for the connection, click on the completion of the operation on the binding success!

Instructions for Braking

- Before riding the vehicle, it is necessary to check whether the front and rear brake handles can work normally
- Excessive sudden braking may cause dead lock and slide of wheel, reducing control over the motorcycle. In this case, release the brake lever and continuously drive forward until the control restores, then brake more gently.
- The ability to brake in turning and emergencies is an important riding skill. We suggest taking a safety basic experience training course for motorcycle drivers to obtain these skills.
- When riding in wet or rainy conditions or on soft ground, the maneuverability and braking capacity of motorcycle will be weakened. In this case, all your actions shall be slowed down; sudden acceleration, braking or turning may lead to loss of control over the motorcycle. For your safety, please be careful in braking, accelerating or turning.
- On long steep road section, intermittent use of brake and continuous braking may overheat the brake and reduce its working effect.
- When riding, if your foot rests on the brake or your hand rests on the brake lever, the stop lamp may be turned on by mistake, giving wrong signal to other drivers; this may also overheat the brake and reduce its working effect.

ABS

ABS is a safety system that prevents the wheels from locking up when traveling in a straight line without lateral traction.

With ABS, full braking power can be utilized without the risk of wheel locking, both under full braking and when the road surface has low traction, such as on sandy, waterlogged, or slippery surfaces.



Attention

Driver assistance can only prevent the vehicle from tipping over within the physical limits. In extreme driving situations, such as a high center of gravity for baggage loading, variable road conditions, steep slopes or failure to release the governor knob for full braking, the vehicle may tip over.

ABS operates using two mutually independent braking circuits (front and rear brakes). If the brake electronics controller detects a tendency for one of the wheels to lock, ABS starts to work by adjusting the brake pressure. This adjustment process can be felt by a slight jump in the front brake handle or the rear brake pedal.

After starting the vehicle, the ABS indicator light must come on and go off after starting. If the ABS indicator light does not go out after starting or comes on while driving, a fault exists in the ABS. In this case, the ABS can no longer be activated and the wheels may lock under braking. The braking system itself still works, only the ABS adjustment system has failed.

TCS (Traction Control System)

Its function is to control the traction of the motorcycle through sensors to provide better stability and traction during acceleration or driving.

The main functions of the system are as follows:

1. When the wheels are idling, the motor power is controlled to reduce the tire slippage caused by the loss of tire traction by reducing the current output, which maintains the stability and control of the vehicle.
2. When the motorcycle accelerates sharply, it can help the vehicle control the power output better. When the motorcycle experiences tire slippage, the system reduces the power output of the electric motor to maintain traction and stability.
3. When encountering slippery road surfaces, it can reduce tire slippage and increase traction and stability.

Switching off the vehicle

The SK3 PLUS can be switched off in two ways: with the mechanical key or with the radio remote control.

Method 1: Switching off the vehicle with a mechanical key

1. Fold down the side stand; the "READY" symbol will disappear from the display. The electrical system of the entire vehicle is still in "Park" mode, and the vehicle will not move off when the throttle is opened.
2. Turn the ignition lock to position 3, and the electrical system of the entire vehicle will switch off.

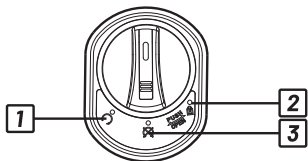

Method 2: Switching off the vehicle with the radio remote control

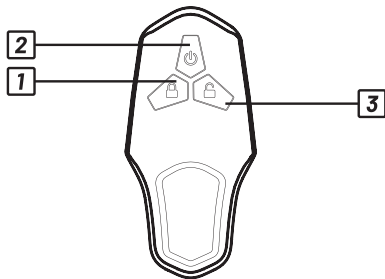

1. Fold down the side stand; the "READY" symbol will disappear from the display. The electrical system of the entire vehicle is still in "Park" mode, and the vehicle will not move off when the throttle is opened.
2. Press button '2' on the radio remote control once, and the entire electrical system will switch off.

Product Manual

Due to the continuous improvement of our products, design changes and other reasons, the product described in this manual may be inconsistent with the product you purchased. Please refer to the actual products.

Maintenance Plan

When a new motorcycle reaches a range of 1000 km or service life of two months (whichever comes first), the first inspection and maintenance shall be carried out in the service center.

Regular inspection and maintenance for each 3000km or 6 months (whichever comes first) are recommended in the service center.

Service Tips

Please turn off the vehicle power before cleaning the vehicle.

Do not flush with strong water jet directly which may cause fault to mechanical components by damp.

Inspection components	Mileage count/time interval (whichever comes first)			
	after the first 1000 km	every 3000 km	every year	every 2 years
<p>Throttle grip</p> <p>Check for damage.</p> <p>If the wear limit is reached or if it is damaged, the component must be replaced.</p>	√	√	√	√
<p>Belt, belt wheels</p> <p>Check for damage</p> <p>If the wear limit is reached or if it is damaged, the component must be replaced. Clean all components.</p> <p>If the belt become loose or other necessary situations, the component must be adjusted.</p>	√	√	√	√
<p>Do not attempt to check belt tension if the belt has been exposed to rain or cleaned within 24 hours, or if the vehicle has been operated at operating temperatures within 4 hours. Cool the vehicle to room temperature before measuring belt tension. If the conveyor belt has been operating for more than 5,000 miles (8,000 km) when it becomes damaged or fails, replace the conveyor belt and both pulleys as a unit.</p> <p>Reminder: Belts and pulleys need to be replaced by professionals, please contact after-sales service or dealer.</p>				
<p>Front/rear brake</p> <p>Check for damage</p> <p>If the wear limit is reached or if it is damaged, the component must be replaced.</p>	√	√	√	√
<p>Brake system</p> <p>Check for damage</p> <p>If the wear limit is reached or if it is damaged, the component must be replaced. Clean all components.</p>	√	√	√	√

Inspection components	Mileage count/time interval (whichever comes first)			
	after the first 1000 km	every 3000 km	every year	every 2 years
Replace the brake fluid (**)				√
Lights, Switch combinations Check for damage. If the wear limit is reached or if it is damaged, the component must be replaced. If necessary, the component must be adjusted.	√	√	√	√
Side stand and main stand Check for damage If the wear limit is reached or if it is damaged, the component must be replaced. Clean and lubricate all components.	√	√	√	√
shock absorber and linkage Front fork Check for damage If the wear limit is reached or if it is damaged, the component must be replaced. Clean all components.	√	√	√	√
Tight fit of all visible screws and nuts(*) Check for damage If the wear limit is reached or if it is damaged, the component must be replaced.	√	√	√	√

Inspection components	Mileage count/time interval (whichever comes first)			
	after the first 1000 km	every 3000 km	every year	every 2 years
<p>Tires, Rims</p> <p>Check for damage</p> <p>If the wear limit is reached or if it is damaged, the component must be replaced.</p>	√	√	√	√
<p>Steering head bearing (* *)</p> <p>Check for damage</p> <p>If the wear limit is reached or if it is damaged, the component must be replaced.</p>	√	√	√	√
<p>Battery</p> <p>Check for damage</p> <p>If the wear limit is reached or if it is damaged, the component must be replaced.</p> <p>The batteries must be charged completely.</p>	√	√	√	√
<p>Motor (* *)</p> <p>Check for damage</p> <p>If the wear limit is reached or if it is damaged, the component must be replaced.</p>	√	√	√	√
<p>(*) Unless you have the appropriate tools, service data and mechanical qualifications, otherwise, the vehicle shall be inspected by your HORWIN authorized dealer.</p> <p>(***) For safety reasons, we recommend that these items can only be provided by your authorized HORWIN dealer. The inspection intervals must be observed, otherwise there is no guarantee!</p>				

Troubleshooting

Troubleshooting of the Whole Vehicle		
Phenomenon	Cause	Treatment Method
Turn on the power switch and the vehicle has no power output	The vehicle is not powered	Treatment Method 1 Check whether the connectors of the battery are plugged on the vehicle properly 2 The battery is under undervoltage condition, please charge the battery
Turn on the power switch, rotate the speed regulating handle, the motor is not started	<ol style="list-style-type: none"> 1. The vehicle is in a braking state 2. The vehicle is in a parking state 3. The side stand is not retracted 4. The start switch has failure 5. The braking handle is not reset 	<ol style="list-style-type: none"> 1. Check whether the vehicle is in a braking state 2. Retract the side stand 3. Contact the after-sales service personnel and check the automatic switch
The endurance mileage is insufficient	<ol style="list-style-type: none"> 1. The battery is not fully charged 2. The tire pressure is insufficient 3. The vehicle is braked and started frequently and the vehicle is overloaded 4. The battery is aged or normally attenuated 5. The environmental temperature is too low and the battery capacity is reduced 	<ol style="list-style-type: none"> 1. Check the charger for damage 2. Check the tire pressure before each use 3. Develop good driving habits 4. Replace the battery 5. Normal phenomenon
The battery cannot be charged	<ol style="list-style-type: none"> 1. The charger plug is not inserted into the socket properly 2. The battery temperature is excessively low 3. The battery temperature is excessively high 	<ol style="list-style-type: none"> 1. Check whether the plug is loose 2. Wait until the battery temperature is the charging temperature 3. Contact the after-sales personnel to check the battery status
The mobile phone cannot be charged through the USB interface	<ol style="list-style-type: none"> 1. USB cable plug is not plugged in the interface properly 2. USB cable fails to meet the mobile standard 3. The USB charger is damaged 	<ol style="list-style-type: none"> 1. Check whether the cable plug is plugged in the USB interface properly 2. Please buy a connecting cable that meets the mobile standard 3. Contact the after-sales service personnel, Replace damaged parts

Fault code (M+)

Fault code (M+)	Fault	Treatment Method
1	Controller fault	Replace the controller
2	Controller fault	Replace the controller
3	Controller fault	Replace the controller
4	Controller fault	Replace the controller
5	Controller fault	Replace the controller
6	Motor fault	Check motor circuit or replace motor
7	Controller fault	Replace the controller
8	Controller fault	Replace the controller
9	Controller fault	Replace the controller
10	Controller over-current fault	Check whether the circuits are short -circuited or replace the controller
11	Hall fault	Check motor circuits or replace motor
12	Motor fault	Check motor circuits or replace motor
13	Motor fault	Check the motor circuits or replace the motor/controller
14	Motor fault	Check the motor or replace the controller

Fault code (M+)	Fault	Treatment Method
15	Handlebar fault	Check the handlebar circuit or replace the handlebar or controller
16	Motor over-temperature protection	Stop for a while before riding or replace the motor
17	Controller over temperature protection	Stop for a while before riding or replace the controller
18	Controller over-voltage protection	Check the voltage of battery
19	Controller under-voltage protection	Check the voltage of battery or charge the battery
20	Controller fault	Replace the controller
21	Brake fault	Check the brake power-off circuit
22	Motor stall protection	Check the motor circuit or replace the motor or controller
23	Motor stall protection	Check the motor or replace the controller
24	Controller circuit fault	Check the positive and negative circuit or check the battery
25	Controller electric key lock fault	Check the main lock circuit or main lock
26	Motor or controller fault	Check the motor line sequence or replace the motor/controller
27	Motor or controller fault	Check the motor line sequence or replace the motor/controller
28	Controller fault	Replace the controller
29	Controller fault	Replace the controller
30	Controller fault	Replace the controller

Failure code (B+)	Fault	Treatment Method
1	Battery Fault	Leave the battery for a while or replace the battery
2	Battery Fault	Leave the battery for a while or replace the battery
3	BMS fault	Re-plug the discharge port plug or replace the battery
4	BMS fault	Re-plug the discharge port plug or replace the battery
5	BMS fault	Leave the battery for a while or replace the battery
6	BMS fault	Re-plug the charging port or replace the battery
7	BMS fault	Re-plug the discharge port plug or replace the battery
8	BMS fault	Re-plug the discharge port plug or replace the battery
9	BMS fault	Re-plug the discharge port plug or replace the battery
10	BMS fault	Re-plug the discharge port plug or replace the battery
11	Low temperature protection	Use the battery in an environment above -15°C
12	BMS fault	Re-plug the discharge port or replace the battery
13	Battery over-voltage warning	Re-plug the charging port or replace the charger
14	Battery over-voltage protection	Re-plug the charging port or replace the charger
15	Battery over-temperature warning	Leave the battery for a while or replace the battery or charger

Failure code (B+)	Fault	Treatment Method
16	Battery over-temperature protection	Leave the battery for a while or replace the battery or charger
17	Battery charging low temperature warning	Place the battery in an environment above 0°C for charging
18	Battery charging low temperature protection	Place the battery in an environment above 0°C for charging
19	Battery charging over-current warning	Check the charger
20	Battery charging over-current protection	Check the charger
21	Battery over-voltage warning	Leave the battery for a while or check the battery voltage or replace the battery
22	Battery over-voltage protection	Leave the battery for a while or check the battery voltage or replace the battery
23	Charger communication fault	Re-plug the charging port or replace the charger or replace the battery
24	Battery discharging under-voltage warning	Charging the battery or replace the battery
25	Battery discharging under-voltage protection	Charging the battery or replace the battery
26	Battery discharging over-temperature warning	Leave the battery for a while or replace the battery
27	Battery discharging over-temperature protection	Leave the battery for a while or replace the battery
28	Battery discharging low-temperature warning	Use the battery in an environment above -15°C
29	Battery discharging low-temperature protection	Use the battery in an environment above -15°C
30	Battery discharging over-current warning	Re-plug the discharge port or replace the battery

Failure code (B+)	Fault	Treatment Method
31	Battery discharging over-current protection	Re-plug the discharge port or replace the battery
32	Battery under-voltage protection	Charging the battery or replace the battery
33	Battery under-voltage warning	Charging the battery or replace the battery
34	Discharge short circuit protection	Re-plug the discharge interface or check the discharge circuit or replace the battery
35	Reverse charging over-current warning	Replace the controller or battery
36	Reverse charging over-current protection	Replace the controller or battery
37	Low insulation of the positive pole of the battery	Re-plug the battery discharge plug or replace the battery
38	Low insulation of the negative pole of the battery	Re-plug the battery discharge plug or replace the battery
39	Battery anti dismantling protection	Use your handheld device to reset or replace the battery

Cleaning of the Vehicle



Please mix tap water and neutral detergent to clean the vehicle. After cleaning the vehicle, wipe the surface with a soft cloth.

Do not clean your vehicle directly with a strong jet of water (e.g., high-pressure cleaner, etc.), which can cause faults or damage to mechanical and electrical components due to moisture.

Wash your vehicle with cold fresh water immediately after driving on roads with high salt spray or near the sea. Do not use warm water, which accelerates the chemical reaction of salt. After drying the vehicle, apply anti-rust oil and anti-corrosion oil to the non-coated metal surface for protection.

Please refer to the more detailed information and instructions in the separate service and maintenance manual.

Secure storage of the vehicle

Please park the vehicle in a flat, solid, well-ventilated and dry place. Please avoid exposing the vehicle to weather conditions such as sunlight, rain/snow, etc. for long periods of time. If you park the vehicle for a longer period of time, please note the additional information in the service/maintenance booklet.

Basic Parameter

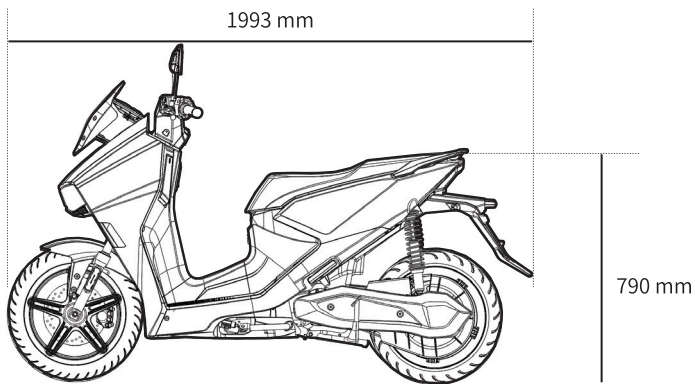

Basic Parameter

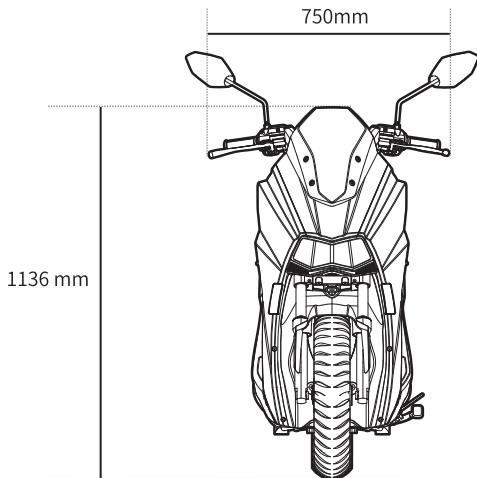

HORWIN SK3 PLUS

DIMENSIONS



Length: 1993mm
Width: 750mm
Height: 1136mm
Seat height: 790mm

Motor Type	Mid-motor
Controller	Field Oriented Vector Control (FOC)
Battery	72 V, 45 Ah*2

MEASUREMENTS

Front Tyre	100/80-14	Max.Permissible	
Rear Tyre	120/70-14	Total Weight	292kg
Wheelbase	1360mm	Empty Weight	104kg (without battery)
Min.ground Clearance	155mm	Rim	Aluminium Alloy

SPECIFICATION

Rated Power	4.5kW	Braking System	ABS+TCS+disc Brakes
Max.Power	8.64kW	Charging Time (10A)	About 5.5h*2(2 batteries)
Max.Speed	100km/h	Max.Range (EEC test)	(WMTC stage3 test)130 km (with 2 batteries)

HIGHLIGHTS

APP	Yes	Electronic Anti-theft System	GPS+Transaction Alarm
All-around LED Lights	Yes	Tailstock/Windscreen	Optional
Reverse Gear	Yes	Y-cable	Basic
Screen	TFT		

Warranty Registration Form

Year:		Model:	
VIN No.:			
Motor No.:			
Date of purchase:			
User name:			
User Address:			
User Contact number:			

Note: This form shall be completed by the customer and shall be filed by the dealer.

Policy of Warranty

Thank you very much for purchasing SK3 PLUS electric motorcycle produced by HORWIN. In order to provide users with comprehensive service guarantee, according to relevant laws and regulations and relevant national regulations on after-sales service, and in combination with product characteristics, the specific provisions about the after-sales service are as follows:

Of the whole vehicle are guaranteed for two years or a total mileage of 20,000 kilometers, whichever comes first, and the Standard Instructions on Three Guarantees is the implementation basis.

Within the warranty period, HORWIN service provider will freely provide repair service and replacement service. If the maintenance is beyond the service period or scope of "Three Guarantees", HORWIN service provider will provide paid services according to local market conditions and maintenance prices.

For the sold products, the warranty period starts from the date of signature for express delivery.

Warranty Standards of Spare Parts

Parts Name	Warranty Standard	Warranty Exemption	Warranty Period
Lithium battery pack	The company provides warranty for lithium batteries after being fully charged in the specified use environment and are not subject to external force impact and have abnormal voltage, cannot be charged, and have less than 70% capacity .And the warranty period for replaced battery is calculated base on the remaining date of warranty period of the original battery).	1. Self-disassembly of the battery pack may cause damage to the internal battery cell connection (because of the complex internal battery pack cell connection, it is not recommended that the user disassemble the battery pack)	24 months or 20,000 km, whichever comes first
		2. Damages caused by failure to comply with battery storage, protection, maintenance requirements. e.g. The battery is under-voltage or cell down caused by long-term non-use of the vehicle or failure to charge in time.	
Motor	Quality problems which cannot be repaired like open phase or burn-out of coil, demagnetization or loss of magnetic steel and so on.	1.Damage to internal circuit of motor caused by unauthorized dis-assembly	24 months or 20,000 km, whichever comes first
		2. Motor damage caused by human factors.	
Frame	1. Loss weld, incomplete and missing welding of the weld joints	1. Damage caused by human factors or improper use	24 months or 20,000 km, whichever comes first
	2.Cracks in key area, or frame fracture.	2.Unauthorized modifications of frame structure	
	3. Failure to apply license plate due to the unclear VIN code.	3. Unauthorized modifications of body structure	

Parts Name	Warranty Standard	Warranty Exemption	Warranty Period
Display	1.No display or incomplete display of the LCD panel.	Scratches or damage to instrument from human factors	24 months or 20,000 km whichever comes first
	2.Inaccurate digit of the LCD panel.		
	3. Date shows abnormally.		
Charger	1. Charge failure caused by Charging harness defect.	1. Modifications of internal structure or wire.	24 months
	2. The indicator doesn't turn to red.	2. No fault after testing	
Converter	1.Internal damage, or voltage regulation failure	No fault after testing	24 months or 20,000 km whichever comes first
	2. No DC output, or over-voltage.		
Controller	Due to product reasons,the performance failure or quality problem occurs and cannot repaired	Damage resulting from unauthorized modifications of the internal circuit or structure of the controller	24 months or 20,000 km whichever comes first

Parts Name	Warranty Standard	Warranty Exemption	Warranty Period
Main Cable	1. During proper use, problems like short circuit, open circuit, ablation and other problems, etc. that cannot be repaired occurs (caused by the caused by defects in the main cable).	1. Unauthorized modifications of the circuit or damage caused by human factors.	24 months or 20,000 km whichever comes first
	2. Circuit defects not caused by improper installation	2. Tearing or abrasion in cable surface (not structural problem)	
Center Control	1. Communication fault	1. Damage caused by unauthorized repairs.	24 months or 20,000 km whichever comes first
	2. Port output fault	2. Unauthorized modifications	
	3. Phonetic function fault	3. Improper operation or use	
	4. Remote key fault.	4. Damage caused by abnormal environment.	
	5. System halt	5. Damage caused by human factors or irresistible natural disasters.	
Steering Column	1. The weld between the steering column riser and the upper connecting plate is loose.	Deformation or damage caused by human factors or improper use.	24 months or 20,000 km whichever comes first
	2. Crack, fracture		
Rear Fork	Fracture, loose weld	1. Damage caused by human factors or improper use.	24 months or 20,000 km whichever comes first
		2. Damages caused by modifications.	

Parts Name	Warranty Standard	Warranty Exemption	Warranty Period
Shock Absorber	1. The front shock absorber is in normal use, and the lower base cylinder fork tube is broken	1. Oil leakage caused by significant damage due to improper use	24 months or 20,000 km whichever comes first
	2. Serious oil leakage in the oil seal area.	2. The parts have been replaced, removed and cannot be restored	
	3. The rear shock absorber is leaking oil and the joint is desoldering.	3. Obvious bumps of shock absorber (Sensory factors)	
	4. The piston rod of the rear shock absorber damper is broken.	4. Soft or hard shock absorber (Sensory factors)	
		5. Rod deflection of rear shock absorber caused by modification or overload	
Wheel Hub	1. wheel hub/rim peeling or breaking	1. Wheel hub deformation and scratches or damage caused by improper maintenance and overload	24 months or 20,000 km whichever comes first
	2. Quality problems of front wheel hub that cause the brake disc stuck and fail to rotate	2. Deformation caused by collision	
	3. Fracture of wheel hub		
	4. Deformation of the hub or wheel		
Rear Armrest	1. Rust of plating layer	1. Damage caused by improper use, scratches, collision or overload.	24 months or 20,000 km whichever comes first
	2. Plating layer detachment, fracture	2. Deformation caused by collision	
Horn	Malfunction caused by structure and quality problems	No errors after testing	24 months or 20,000 km whichever comes first

Parts Name	Warranty Standard	Warranty Exemption	Warranty Period
Lock Set	1. The front lock failure	1. Lock set was broken caused by human factor	24 months or 20,000 km whichever comes first
	2. Battery lock failure	2.Damages caused by improper use.	
	3. Remote control failure		
Brake System	1. Breakage or falling off due to material problems	1. Improper disassembly of the hydraulic disc brake upper and lower pump assemblies leads to oil leakage	24 months or 20,000 km whichever comes first
	2. Brake failure of hydraulic braking system caused by leakage of gas, air resistance, decreased pump pressure, or brake caliper seizing	2. Malfunction of hydraulic disc brake caused by lack of oil instead of damage	Brake disc and brake pads and brake oil are not included
	3. Brake uninterrupted and cannot be repaired	3. Worn-out of brake disc	
		4. Brake system damage caused by self-modification	
Throttle	Unable to adjust speed due to circuit and structural problems	Abnormal throttle caused by improper use	24 months or 20,000 km whichever comes first
Headlight	Malfunction caused by quality problems.	Damage caused by unauthorized circuit modification.	24months or 20,000 km whichever comes first
Taillight			
Turn Signal			
Rear License Light			
Left/right Switch Assembly	1. Switch failure, failure to be seat or reset	1.Unauthorized circuit modifications	24 months or 20,000 km whichever comes first
	2. Loose and breakage of switch button because of the quality problems	2. Missing pieces or inconsistency	
	3. Short circuit, open circuit or poor contact inside switch		
	4. Inconsistent switch circuit		

Parts Name	Warranty Standard	Warranty Exemption	Warranty Period
Side Stand	Fracture or loose weld	1. Deformation or damage caused by human factors or improper use	24 months or 20,000 km whichever comes first
		2. Scratches or damage to surfaces caused by human factors	
		3. Self-modification or self-repair such as welding, etc	
Seat Cushion	Bursting or cracking caused by quality problem	Breakage and fracture of the cushion surface caused by human factors	24 months
Exterior Plastic Parts	If the area of peeling or crack that caused by the paint problem is more than 1 CM ² , the part can be replaced	Damage caused by human factors	24 months
Tire	Cracking, swelling or bursting	1. Normal wearing	6 months
		2. Damage caused by human factors	
		3. External damage	
Vulnerable parts	Non-warranty parts: bulbs, brake pads, brake fluid, rear mirrors, power sockets, in-haul cables, USB port , PP parts, screws, nuts and other standard parts, decorative parts, fuses, chains, vulnerable and consumable parts.	No warranty	

Instructions to other items not covered by warranty standard

Based on the above table, if the items are beyond the time limit and scope of three guarantees, they are beyond the scope of three-guarantee service.

- Other parts not included in the above table, such as brake shoe, brake oil, power socket, cable, USB, PP and appearance parts, are vulnerable and consumable parts and cannot enjoy the "Three-Guarantee" service.
- Normal maintenance services, including but not limited to: replacing gear oil, checking tires, checking brakes, adjusting brakes, changing brake fluid, checking electrical system, checking chain tension, adjusting chain tension, replacing chains and checking battery packs, are not within the scope of "Three Guarantees".
- Advertising promotion items, gift items, sound volume, touch-sense items and other sensory & cognitive items.
- Damage caused by smoke, earthquake, typhoon, flood, fire, lightning strike, chemical corrosion and other force majeure factors.
- If the vehicle is not repaired by the service provider, the parts are modified, decomposed and damaged by the user, other parts are damaged due to use of non-original parts, and the circuit and configuration are modified by the user without authorization, the user will not enjoy the Three-Guarantee service.
- Damage caused by human factors such as crash, falling, overspeed, overload, unauthorized modification, failure to use original parts, failure to operate the vehicle according to operating instructions.
- There is no invoice, warranty card or bill or the bill is inconsistent with the card.
- If the parts such as controller and charger are provided with trademarks or seals, and the trademarks or seals are torn artificially, these parts will not be guaranteed.
- The user fails to use and maintain the battery normally, the storage time exceeded 2 months (the battery is plugged into the vehicle and stored for more than 15 days; the initial power is less than 50% and the battery is stored separately for more than 2 months), and the battery is not charged in time, therefore the battery feeding and undervoltage are caused and the faults are irreparable.

Repair & Maintenance Records

In order to enhance your warranty experience, please be sure to repair and maintain your vehicle at our authorized dealers. And please record in the form below and stamp the dealer's seal.

Model:	Frame No.:	Motor No.:
The 1st service		Dealer's stamp
Date:		
Range:		
The 2nd service		Dealer's stamp
Date:		
Range:		
The 3rd service		Dealer's stamp
Date:		
Range:		
The 4th service		Dealer's stamp
Date:		
Range:		
The 5th service		Dealer's stamp
Date:		
Range:		
The 6th service		Dealer's stamp
Date:		
Range:		

The 7th service	
Date:	
Range:	Dealer's stamp
The 8th service	
Date:	
Range:	Dealer's stamp
The 9th service	
Date:	
Range:	Dealer's stamp
The 10th service	
Date:	
Range:	Dealer's stamp
The 11th service	
Date:	
Range:	Dealer's stamp
The 12th service	
Date:	
Range:	Dealer's stamp
The 13th service	
Date:	
Range:	Dealer's stamp
The 14th service	
Date:	
Range:	Dealer's stamp

The 15th service	
Date:	
Range:	Dealer's stamp
The 16th service	
Date:	
Range:	Dealer's stamp
The 17th service	
Date:	
Range:	Dealer's stamp
The 18th service	
Date:	
Range:	Dealer's stamp
The 19th service	
Date:	
Range:	Dealer's stamp
The 20th service	
Date:	
Range:	Dealer's stamp

HORWIN

HORWIN Headquarter

Building 1 | No.5 Chuangzhi Road | Tianning District

Changzhou | Jiangsu | China

Phone.: +86 400-778-6688 | Email: horwin@horwinglobal.com

www.horwin.com

